

TRIFAB® VG 450 SHOWN  
(400 & VG 451 SIMILAR)

### ASSEMBLY AND INSTALLATION

\* IN DOOR  
PACKAGE

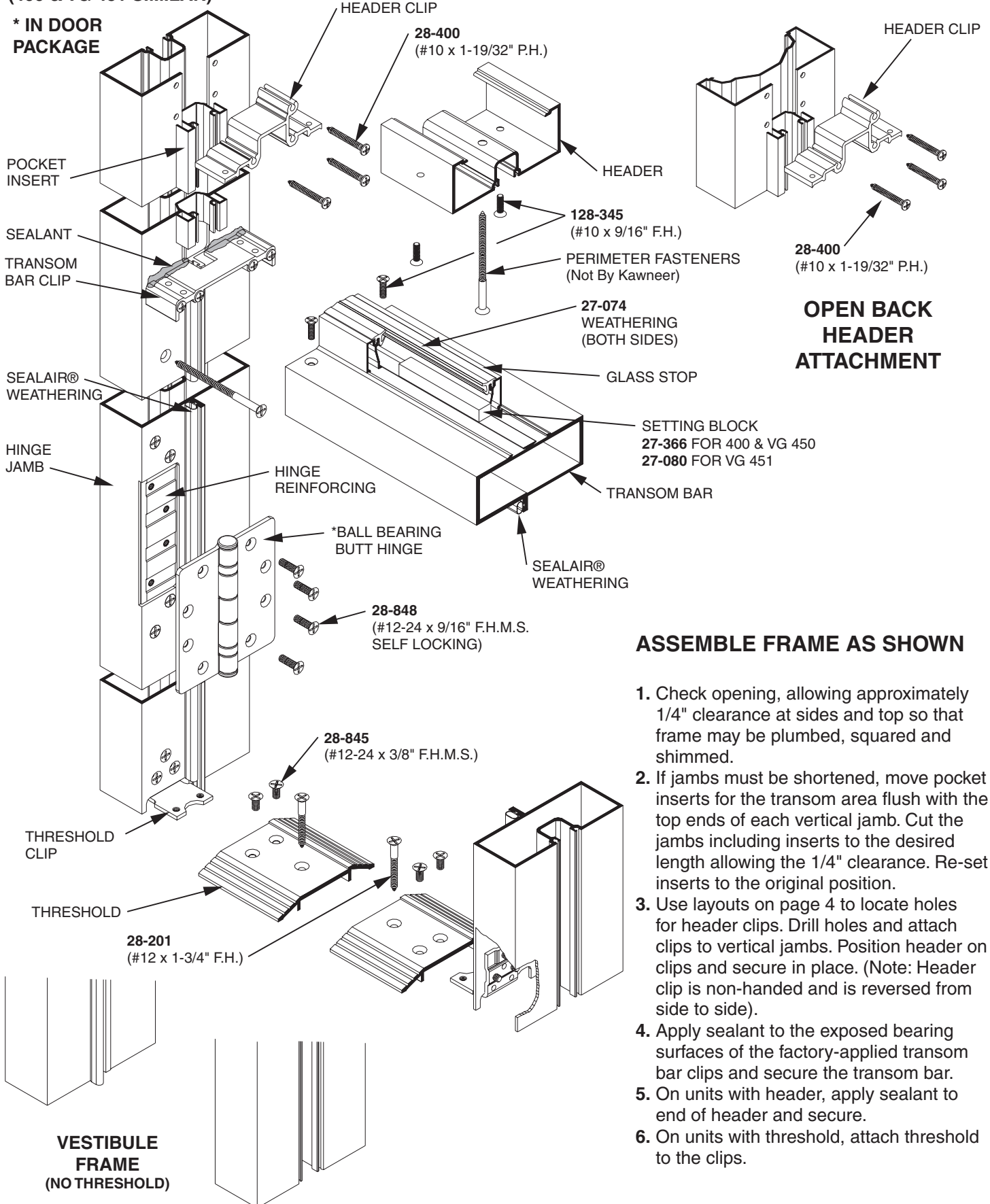

### ASSEMBLE FRAME AS SHOWN

1. Check opening, allowing approximately 1/4" clearance at sides and top so that frame may be plumbed, squared and shimmed.
2. If jambs must be shortened, move pocket inserts for the transom area flush with the top ends of each vertical jamb. Cut the jambs including inserts to the desired length allowing the 1/4" clearance. Re-set inserts to the original position.
3. Use layouts on page 4 to locate holes for header clips. Drill holes and attach clips to vertical jambs. Position header on clips and secure in place. (Note: Header clip is non-handed and is reversed from side to side).
4. Apply sealant to the exposed bearing surfaces of the factory-applied transom bar clips and secure the transom bar.
5. On units with header, apply sealant to end of header and secure.
6. On units with threshold, attach threshold to the clips.

## ASSEMBLY OF TRIFAB® VG 450 AND VG 451 FRONT OR BACK TRANSOM ADAPTER

1. With the frame assembled, place the transom adapter on top of the transom bar . Align adapter with the front or back edge of transom bar as required. Using the holes provided in the adapter as a template, match drill the transom bar with a #26 (.147" dia.) drill.
2. Prior to attaching the adapter, apply a bead of silicone to the transom bar as shown.
3. Secure the adapter in place with #28-710 (#10 x 5/8") or 28-354 (#10 x 1/2") fasteners.

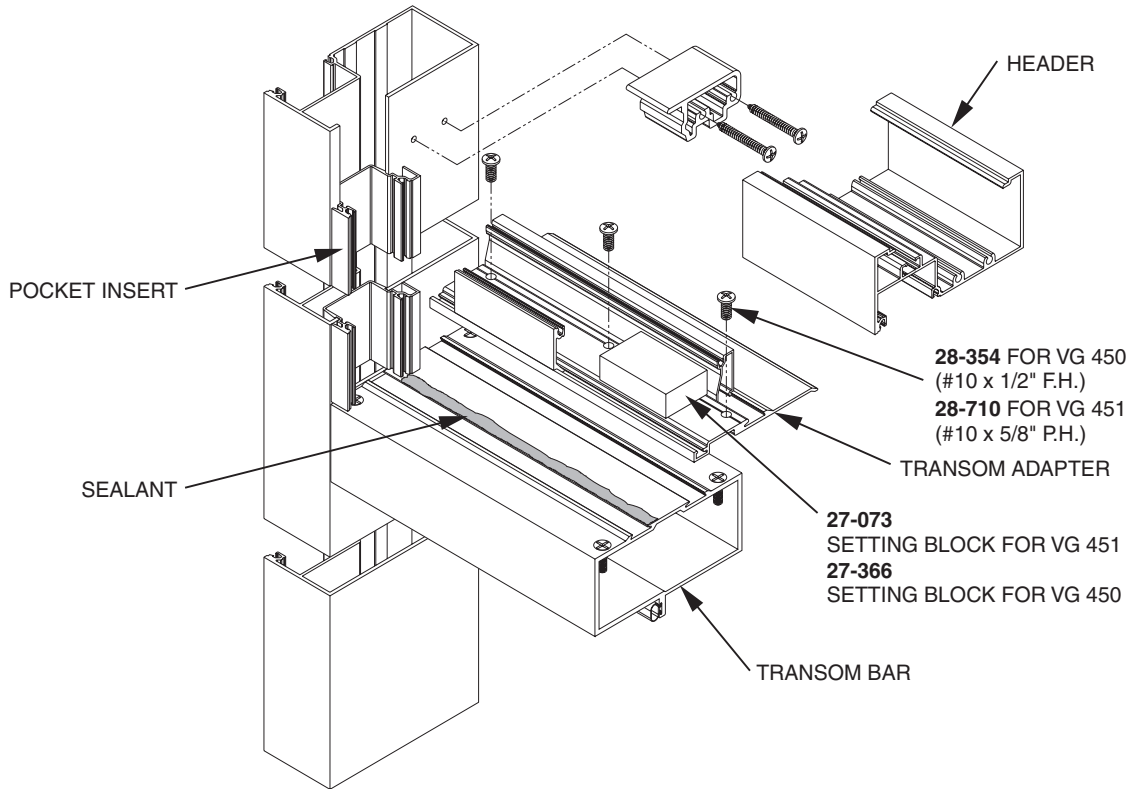

## INSTALLATION OF ASSEMBLED FRAME

1. Position assembled frame plumb and square in opening. Drill and countersink anchor holes for #12 F.H. screws. Holes should be started 6" from the bottom of each jamb, and not more than 36" on center. Drill 1/2" clearance hole in pocket insert of jamb so head of screw sets on jamb, not the insert. Drill 3 holes evenly spaced through the glazing pocket of header.
2. Set threshold in a bed of sealant or mastic.
3. Shim and secure jambs and header in opening.
4. Secure the threshold (if supplied) to the floor.
5. Install closer per instructions included in closer package.
6. Glaze the transom:
  - A. Snap interior glass stop on to transom bar. Apply bead of sealant to base of front leg of the glass stop where it meets the top of the transom bar, or transom bar adapter.
  - B. Pre-cut horizontal and vertical Push-On gasket allowing approximately 1/4" per foot extra.
  - C. Insert interior Push-On gasket into glass stop and remaining 3 glazing pockets (vertical transom jambs and header). Run horizontal gaskets through and butt vertical gaskets in between.
  - D. Position glass into transom area and place setting blocks on the transom bar at 1/4 points.
  - E. Install remaining glass stop into the transom bar. Install exterior Push-On gaskets into glazing pockets.

# TRANSOM AREA GLASS SIZE

**400 & VG 450 CENTER  
(SINGLE GLAZING)**

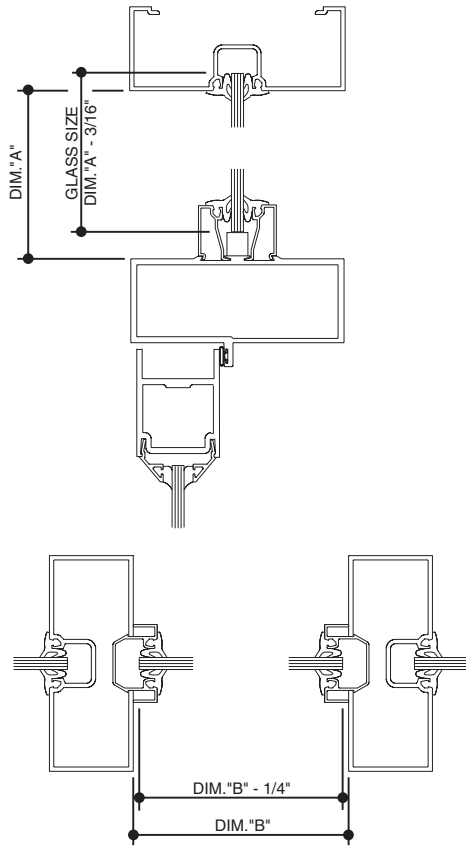

**VG 451 CENTER  
(DOUBLE GLAZING)**

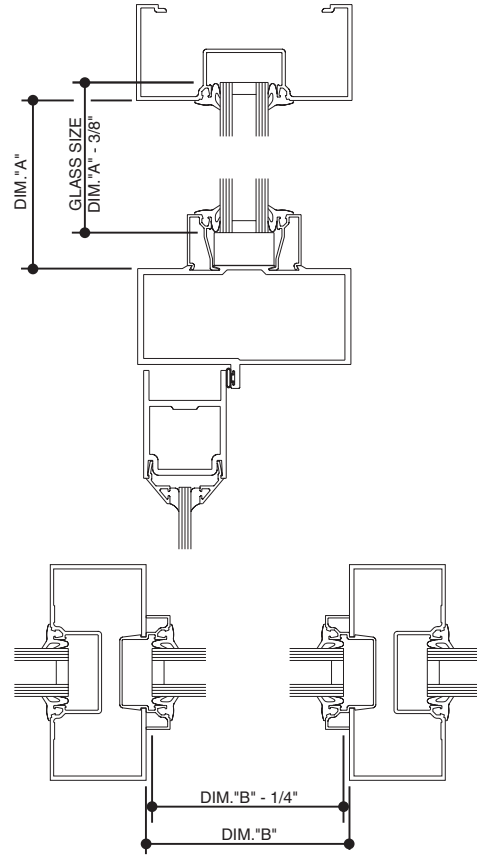

**VG 450 FRONT/BACK  
(SINGLE GLAZING)**

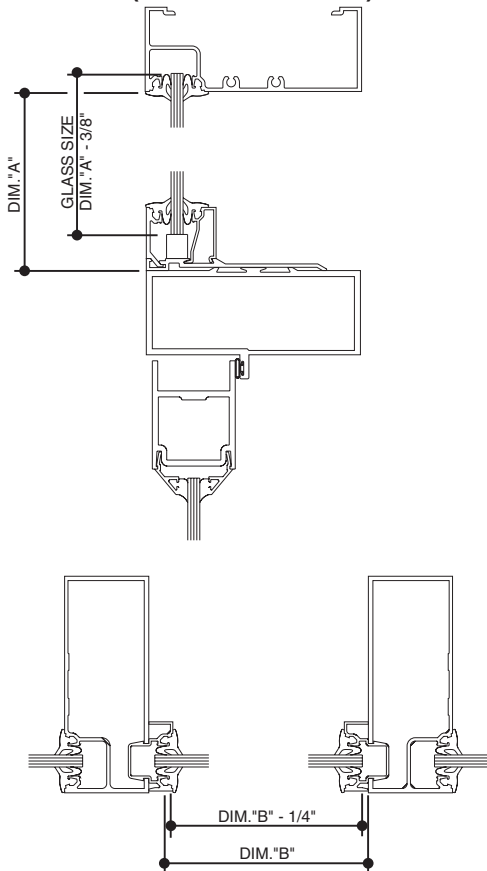

**VG 451 FRONT/BACK  
(DOUBLE GLAZING)**

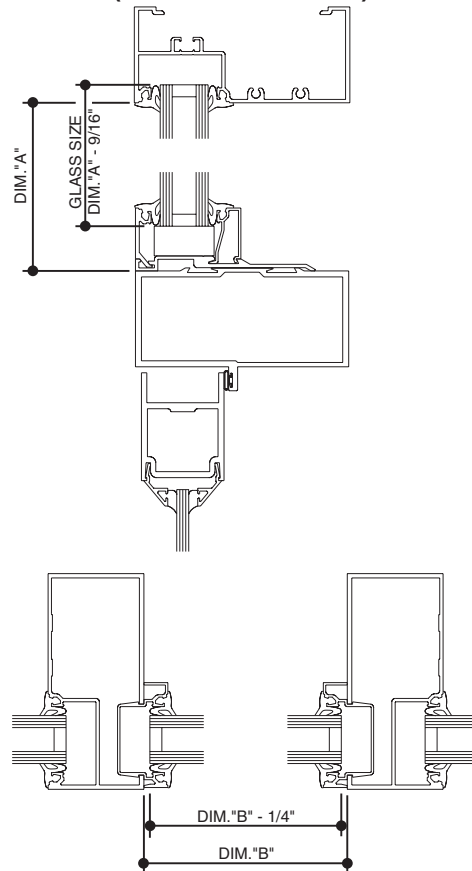

**FIELD MODIFICATION TO STANDARD FRAME WHEN THRESHOLD IS NOT REQUIRED**

1. Remove the threshold clip.
2. Cut threshold clip to clear the glazing pocket, tap all untapped holes for #12-24 screws and reverse the clip inside the lock jamb to act as the nut plate.

